



PROFTECH
SPÓLKA Z O.O.



AB 994

*Research laboratory
accredited by PCA, Nr AB
994*

Scopes of accreditation:

- concentration and mass measurements of flow of fine particles
- measurements of concentration and mass flow of SO₂, NO_x, CO
- concentration measurements of CO₂, O₂
- concentration and mass flow measurements of OWO
- sampling for mass concentration determination of PCDD/PDF and dioxin type PCB
- sampling for concentration determination of (As; Cd; Cr; Co; Cu; Mn; Ni; Pb; Sb; Tl; V)
- sampling for concentration determination of Hg
- sampling and determination of concentration and mass flow of HCl
- sampling and determination of concentration and mass flow of HF
- sampling for determining the concentration of individual gaseous organic compounds
- calibration of Automated Monitoring systems,
- QAL2 procedure
- annual performance test of Automated Monitoring Systems, AST procedure
- noise measurement from machinery, installations and industrial plants

Chorzów, June 17th 2021
Our ref. No.: PW/21/06/21

Report No PW/21/06/21

on concentration measurements of dioxins and furans emitted into environment from flue gas channel located at UAB KAUNO KOGENERACINĖ JĖGAINĖ, Jėgainės g. 6, Biruliškių k., LT-54469 Kauno raj., Lithuania.

Client name and address:

**UAB KAUNO KOGENERACINĖ
JĖGAINĖ,**
Jėgainės g. 6, Biruliškių k.,
LT-54469 Kauno raj.

Developed by:

mgr Grzegorz Bortel

Calculation and data transfer checked by:

inż. Dariusz Guja

Verified by:

inż. Dariusz Guja

Copy number: ...4/4...

ul. Kurta Aldera 44
41-506 Chorzów
tel/fax: 0 32 247 37 24

www.proftech.com.pl
e-mail: proftech@proftech.com.pl

NIP: 627 252 46 31
KRS: 0000773369

bank account : PKO BANK POLSKI S.A. O/Katowice : IBAN PL62 1440 1172 0000 0000 0353 4332

Test Report No PW/21/06/21

List of contents:

- 1. PURPOSE AND SCOPE OF THE REPORT**
- 2. BASIS OF MEASUREMENTS EXECUTION**
- 3. MEASUREMENT TEAM**
- 4. MEASUREMENT RESULTS SUMMARY**
- 5. DESCRIPTION OF THE MEASUREMENT METHOD**
- 6. MEASUREMENT RESULTS**
- 7. MEASUREMENT DEVICES**
- 8. ANALYSIS RESULTS**
- 9. CERTIFICATE OF ACCREDITATION**
- 10. MEASUREMENT PLANE SCHEME**

Test Report No PW/21/06/21**1. PURPOSE AND SCOPE OF THE REPORT**

Purpose of executed measurements was to determine the concentration and emission of dioxins and furans emitted to environment from flue gas channel located at *at* UAB KAUNO KOGENERACINĖ JĖGAINĖ, Jėgainės g. 6, Biruliškių k., LT-54469 Kauno raj., Lithuania.

Measurements range:

- PCDD/DF emission and concentration.

The measurements were carried out in accordance with the sampling plan and the described sampling methods.

Operating parameters of the technological installation was obtained from the customer's representative.

2. BASIS OF MEASUREMENTS EXECUTION

The measurements were taken according to the Contract No 2020-KKJ-05 dated March 31st 2020, our reference number PP/15/03/20.

3. MEASUREMENT TEAM

The measurements taken on May 27th 2021 were executed by the following team:

- Grzegorz Bortel specialist - measurement team leader,
- Grzegorz Kurzeja specialist,
- Karol Sodo technician.

4. MEASUREMENT RESULTS SUMMARY

Below are presented measurement results summary, full measurement results are presented in chapter no 6, at page 8.

Concentration of the substance in the gas in reference conditions O ₂ ref. 11%	PCDDF	ng/m ³	0,006
Emission limits	PCDDF	ng/m ³	0,1
Transgerssion	PCDDF	ng/m ³	-

Test Report No PW/21/06/21

5. DESCRIPTION OF THE MEASUREMENT METHOD**Measurement of the gas volumetric flow**

The flow rate was determined according to ISO Standard PN-EN ISO 16911-1:2013 „Stationary source emissions - Manual and automatic determination of velocity and volume flow rate in ducts - Part 1: Manual reference method". Gravimetric dust monitor type Megasystem APIS X-1 and type "S" Pitot tube were used for the measurements. Measurement is accredited.

Accreditation range: differential pressure: > 5 Pa

Measurement O₂ content

The concentration of O₂ was determined using gas analyzer HORIBA PG-350 EHR equipped with testing probe 2000 mm long. The measurements were taken according to the procedure described in measurement unit as well as to Polish Standard PN-EN 14789:2017 "Stationary source emissions - Determination of volume concentration of oxygen O₂ - Reference method - Paramagnetism". Measurement is accredited.

Accreditation range: O₂ content: 3-21%

Measurement CO₂ content

The concentration of CO₂ was determined using gas analyzer HORIBA PG-350 EHR equipped with testing probe 2000 mm long. The measurements were taken according to the procedure described in measurement unit as well as to Polish Standard PN-ISO 10396:2001 "Stationary Source Emissions - Sampling For The Automated Determination Of Gas Concentrations ". Measurement is accredited.

Accreditation range: CO₂ content: 0,1-20%

Measurement moisture content

Moisture content was determined using condensation-absorption method. The measurements were taken according to Polish Standard PN-EN 14790:2017. Measurement is accredited.

Accreditation range: H₂O content: 29-250 g/m³

Test Report No PW/21/06/21

PCDD+PCDF sampling and determination

PCDD/DF samples were taken according to the requirements of Polish Standard PN-EN 1948-1:2006 „ Stationary source emissions - Determination of mass concentration of PCDDs/PCDFs and dioxin-type PCBs - Part 1: Sampling of PCDDs/PCDFs”.

The three stages of PCDD/DF concentration and emission determination:

Stage I - sampling

For the determination of mass concentration of PCDD/DF proper sampling plays important role that affects following stages of the testing. The sampling were performed by means of the filtration and condensation method using PCDD/DF sampling system conformed to European Standard PN-EN 1948-1:2006.

The following page shows the schematic diagram of the sampling system.

Stage II - laboratory analysis

The samples were analysed at the ALS Czech Republic, s.r.o accredited laboratory following the CSN EN 1948-2,3 methodology: The determination of polychlorinated dibenzo-p-dioxine, dibenzofurans in emission samples with the method of isotop dillution using HRGC/HRMS.

The dioxin and furans analyses were conducted at the ALS Czech Republic, s.r.o. Laboratory, specifically accredited for the test by the Český Institut Pro Akreditaci, o.p.s. , Nr L 1163.

Stage III - development and the results and discussion

The last stage includes results collection from the previous stages, emission calculation and PCDD/DF concentration as well as comparison to the standards in force.

Test Report No PW/21/06/21

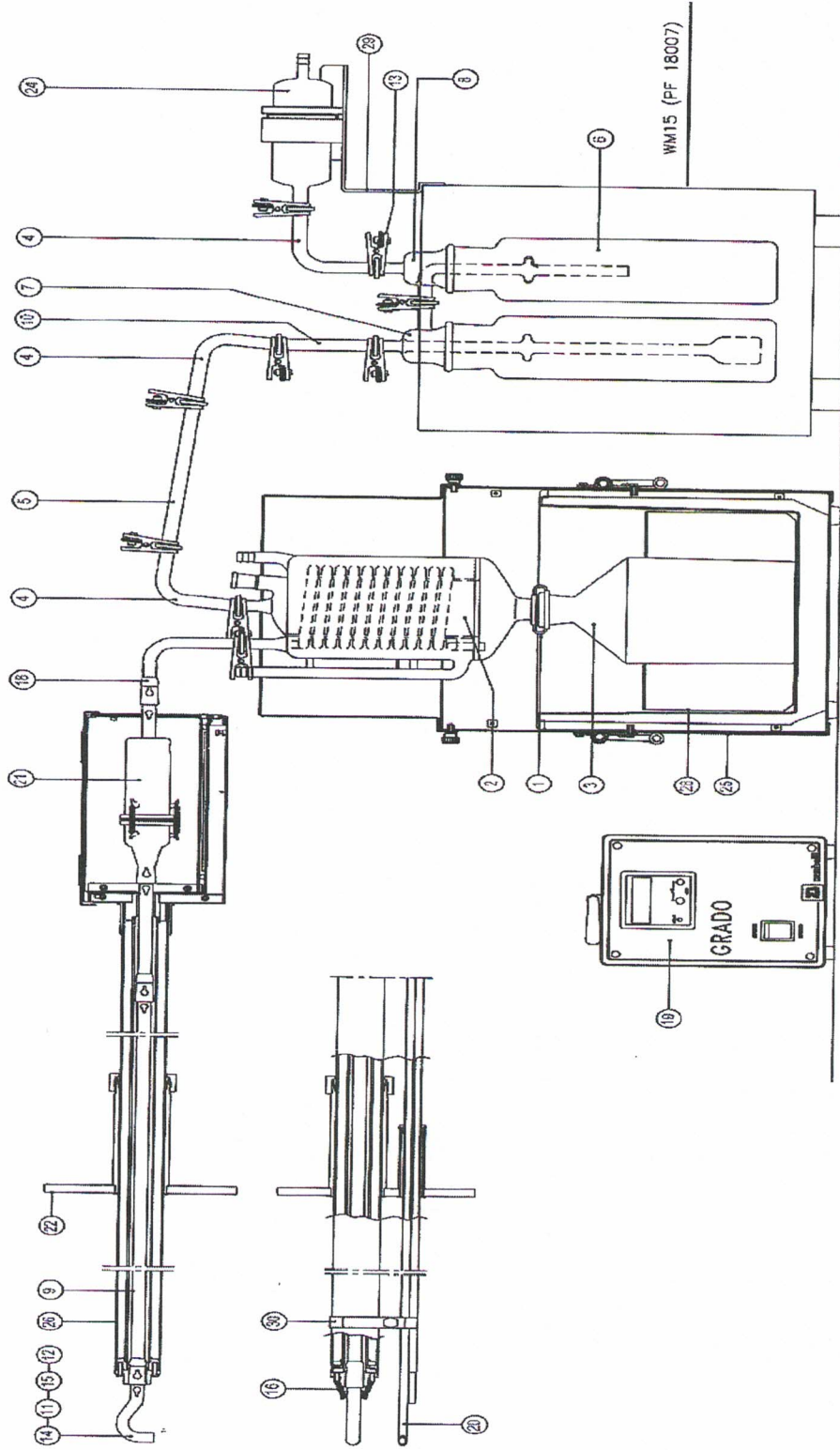

- Opis:
- 1. ferrule
 - 2. cooler
 - 3. condensation pot
 - 4,18. aspiration path - elbows
 - 5,10. aspiration path - tubes
 - 6-8. scrubbers
 - 9. aspiration path - probe tube
 - 11,12,14,15. - aspiration endings
 - 13. clamp
 - 16. holding springs
 - 17. aspiration controller
 - 19. temperature controller
 - 20. Pitot tube „S” - type
 - 21. filter casing
 - 22. yoke
 - 24. gas dryer
 - 25. cooler casing
 - 26. heated probe
 - 28. cooler coil
 - 29,30. support

Test Report No PW/21/06/21

6. MEASUREMENT RESULTS

Test Report No PW/21/06/21

- 1) Plant or unit name: **Combined Heat and Power Plant**
 2) Flue gases cleaning unit: **bag filters, activate carbon, hydrated lime, scrubber**
 3) Emission source load during measurements: **~94,2%**
 4) Fuel type or material mass flow in process: **60% municipal waste, 40% non – hazardous industrial waste / waste code: 19 02 03;**
 5) Location of sampling and measurements: **in duct, after flue gases cleaning unit**

Measurement reference number		27-05-01		X	X		
Date of measurement		27.05.2021					
Measurement time range		10:41-16:45					
Scope of test		Unit	Results	Uncertainty +/-	Method		
Meteorological conditions	Atmospheric pressure		hPa	1001,5	1,6	X	
	Ambient temperature		oC	15			
Cross-section	Diameter		m	2,00			
	Area		m ²	3,14			
The parameters of gas in line	Temperature		oC	44	0,720	X	
	Static pressure		Pa	101	1,070		PN-EN ISO 16911-1:2013
	Differential pressure		Pa	78	0,720		PN-EN ISO 16911-1:2013
	Gas moistness grade X		kg/kg	0,041	0,001		PN-EN 14790:2017
	Average velocity		m/s	10,2	0,6		PN-EN ISO 16911-1:2013
	Chemical composition	O ₂	%	9,3	0,8		PN-EN 14789:2017
		CO ₂	%	9,7	0,4		PN-ISO 10396:2001
	Wet gas density during testing		kg/m ³	1,110			PN-EN 14790:2006
	Gas density in normal conditions		kg/m ³ N	1,302			PN-EN 14790:2006
Gas density in conventional conditions		kg/m ³ U	1,336		PN-EN 14790:2006		
Concentration in the gas at measurement conditions	PCDDF*	ng/m ³	0,006	0,002	PN-EN 1948:2006		
Concentration in the gas at normal conditions	PCDDF*	ng/m ³	0,006	0,002	PN-EN 1948:2006		
Concentration of the substance in the gas in standard conditions	PCDDF*	ng/m ³	0,007	0,002	PN-EN 1948:2006		
Concentration of the substance in the gas in reference conditions O ₂ ref. 11%	PCDDF*	ng/m ³	0,006	0,002	PN-EN 1948:2006		
Gas volume flow	measurement conditions		m ³ /h	115075	14434	X	
	normal conditions		m ³ N/h	98080	12314		
	standard conditions		m ³ U/h	92243	12127		
	reference conditions O ₂ ref. 11%		m ³ U/h	107925	16308		
The emission obtained by measuring	PCDDF*	ng/h	608,81	208,56	PN-EN 1948:2006		
Emission limits	PCDDF*	ng/m ³	0,1		X		
Transgresssion	PCDDF*	ng/m ³	-		X		

*- the results obtained from the subcontractor (accredited)

Test Report No PW/21/06/21**Notes:**

Normal conditions designate the temperature of 273 K and pressure of 101,3kPa, defining normal cubic meter m³N. The standard conditions designate the temperature of 273K, pressure of 101,3 kPa and dry gases (steam contents less than 5 g/kg of flue gas), defining standard cubic meter, m³U

The specified expanded uncertainty comes from standard uncertainty multiplied by expansion coefficient k = 2, which provides 95% level of confidence for normal distribution. Uncertainty takes into account the sampling and analysis.

Registry of samples delivered to the laboratory: P/106/05/21, P/107/05/21

Date of delivery to the laboratory: 28.05.2021

Date of analysis: 28.05 - 15.05.2021

Field blanks:

ID/ number of sample	Type of substance	The criterion of the blank [ng/m ³] 11%O ₂	The value of the blank [ng/m ³] 11% O ₂	Result [+/-]
P/107/05/21	PCDD/DF	0,01	0,002	+

Work parameters of measurement system:**PCDD/DF (PN-EN 1948:2006):**

sampling method: condensation - adsorption method

filter parameters: 19 x 90 mm, filter efficiency: 99,998 %

sampling train: 2 measurement axis

oxygen reference : 11 %

time of dioxins and furans measurement: 10:41 – 16:45 (364,3 min)

nozzle diameter: 8 mm

probe temperature: 120 °C

scrubbers temperature 4 °C

aspired gas volume 9,45 m³

average sampling flow 25,9 l/min

izokinetic ratio: 96,0 %

leak test: + / +

gas meter temperature 21,1 °C

gas meter pressure 0 bar

spiking pattern: filter surface

absorption solution: 100 ml H₂O dest. + 50 ml 2-etoksyetanol

recovery: 79 % ¹³C₁₂-1,2,3,7,8-PECDF, />50%/
67 % ¹³C₁₂-1,2,3,7,8,9-HxCDF, />50%/
69 % ¹³C₁₂-1,2,3,4,7,8,9 HpCDF. />50%/
TEQ sample mass: 0,058 ng

H₂O (PN-EN 14790:2017)

sampling train: 2 measurement axis

sampling equipment: titanium sampling train
heated probe 2,0 m long
sampling pump: PT-02

cartridge: moisture measurement set

number of samplings: 1

sampling time: 31 min

sampling volume: 2,0 l/min

H₂O maas: 2,52 g

absrobtion efficiency: 97,9 %

Test Report No PW/21/06/21Statement of compliance with the specification/requirement:

The average value of the measurement series in the scope of dioxins and furans was assessed for compliance with the value of the emission standard for certain types of installations, fuel combustion sources and waste incineration or co-incineration devices

The laboratory has adopted the simple acceptance principle in accordance with ILAC-G8: 09/2019. The risk of incorrect acceptance / incorrect rejection for a result equal to the requirement / specification is 50%.

Decision-making bodies may adopt a different decision-making principle, which may have an impact on the outcome.

7. MEASUREMENT DEVICES

Name of measuring device		X1- Apis
Type of measuring device		Isokinetic sampler S/N 0142
Certificate	Calibration No	824-2373/19 824-2374/19 824-2372/19 824-2375/19 G-106/20-66/20
Issued by		INTROL Sp. z o.o. KATOWICE ZAP BESTWINKA
Date of issue the certificate of calibration		27.08.2019 28.08.2019 11.03.2020
Expiration date of the certificate of calibration		-

Name of measuring device		HORIBA
Type of measuring device		PG-350E-HR
Certificate	Calibration No	69/1/AW/21
Issued by		Laboserwis Sp. z o.o. Katowice
Date of issue the certificate of calibration		22.03.2021
Expiration date of the certificate of calibration		-

Name of measuring device		Sampler
Type of measuring device		PT-02
Certificate	Calibration No	851-2464/19 786-2246/19 R-287/16-186/16 G-373/19-227/19
Issued by		INTROL Sp. z o.o. KATOWICE ZAP BESTWINKA
Date of issue the certificate of calibration		29.08.2019 12.08.2019 08.08.2019
Expiration date of the certificate of calibration		-

Test Report No PW/21/06/21

8. ANALYSIS RESULTS



Attachment no. 1 to the Certificate of Analysis for work order PR2150673

Sample:

P/106/05/21

Measurement results PCDD/Fs:

Sample:		P/106/05/21		Final extract [µl]:		60	
				Injection volume [µl]:		4	
				Acquisition date [d.m.y h:m]:		10.6.21 12:02	
2,3,7,8-PCDD/Fs	Result [ng/sample]	Limit of Detection [ng/sample]	Limit of Quantification [ng/sample]	¹² I-TEFs	I-TEQ Upperbound [ng/sample]		
2,3,7,8-TCDD	< 0.0045	0.0045	0.0091	1	0.0045		
1,2,3,7,8-PeCDD	< 0.0054	0.0054	0.011	0.5	0.0027		
1,2,3,4,7,8-HxCDD	< 0.0066	0.0066	0.013	0.1	0.00066		
1,2,3,6,7,8-HxCDD	< 0.0066	0.0066	0.013	0.1	0.00066		
1,2,3,7,8,9-HxCDD	< 0.0066	0.0066	0.013	0.1	0.00066		
1,2,3,4,6,7,8-HpCDD	0.07	0.013	0.027	0.01	0.0007		
OCDD	0.048	0.015	0.03	0.001	0.000048		
2,3,7,8-TCDF	0.042	0.0042	0.0084	0.1	0.0042		
1,2,3,7,8-PeCDF	0.031	0.0045	0.0091	0.05	0.0016		
2,3,4,7,8-PeCDF	0.051	0.0045	0.0091	0.5	0.026		
1,2,3,4,7,8-HxCDF	0.038	0.0061	0.012	0.1	0.0038		
1,2,3,6,7,8-HxCDF	0.078	0.0061	0.012	0.1	0.0078		
1,2,3,7,8,9-HxCDF	< 0.0061	0.0061	0.012	0.1	0.00061		
2,3,4,6,7,8-HxCDF	0.031	0.0061	0.012	0.1	0.0031		
1,2,3,4,6,7,8-HpCDF	0.12	0.0097	0.019	0.01	0.0012		
1,2,3,4,7,8,9-HpCDF	< 0.0097	0.0097	0.019	0.01	0.000097		
OCDF	< 0.012	0.012	0.024	0.001	0.000012		
I-TEQ from quantified 2,3,7,8-PCDD/Fs - "Lowerbound"						0.048	
I-TEQ from 2,3,7,8-PCDD/Fs - "Mediumbound"						0.053	
Maximum possible I-TEQ - "Upperbound"						0.058	
PCDDs	Result [ng/sample]	PCDFs		Result [ng/sample]			
Tetra-CDDs	< 0.1	Tetra-CDFs		4.6			
Penta-CDDs	< 0.075	Penta-CDFs		2.2			
Hexa-CDDs	< 0.066	Hexa-CDFs		0.69			
Hepta-CDDs	0.22	Hepta-CDFs		0.12			
OCDD	0.048	OCDF		< 0.012			

¹²I-TEF according to NATO.

Limits of quantification are defined as double of the detection limits.

The limit of detection is defined as the amount of analyte producing a signal with S/N>3.

The value of the detection limit is mentioned as the actual value at the acquisition date.

Measurement uncertainty is expressed as a double (k=2) relative standard deviation (RSD%), and corresponds to 95% confidence interval.

Estimation of uncertainty of each 2,3,7,8-PCDD/F congener is 30% and total I-TEQ is 20%.

These values were ensured by analyses of certified reference material under conditions of internal reproducibility.

Results marked with "<" are below limit of detection or quantification.

"Lowerbound" and "Upperbound" are levels defined in Regulation 2017/644 and EN 1948-4.

"Mediumbound" is levels defined in Regulation 2017/644.

Test Report No PW/21/06/21



Attachment no. 1 to the Certificate of Analysis for work order PR2150673

Sample:

P/106/05/21

Standards recovery:

Sample: P/106/05/21					
Final extract [µl]:					60
Injection volume [µl]:					4
Acquisition date [d.m.y h:m]:					10.6.21 12:02
Extraction standard	Recovery [%]	Acceptable range [%]		Accept. rec. with respect to	
		Basic	Extended	basic range	extended range
PCDDs					
13C12 - 2,3,7,8-TCDD	56	50 - 130	30 - 150	YES	-
13C12 - 1,2,3,7,8-PeCDD	69	50 - 130	30 - 150	YES	-
13C12 - 1,2,3,4,7,8-HxCDD	53	50 - 130	30 - 150	YES	-
13C12 - 1,2,3,6,7,8-HxCDD	62	50 - 130	30 - 150	YES	-
13C12 - 1,2,3,4,6,7,8-HpCDD	71	40 - 130	20 - 150	YES	-
13C12 - OCDD	61	40 - 130	20 - 150	YES	-
PCDFs					
13C12 - 2,3,7,8-TCDF	68	50 - 130	30 - 150	YES	-
13C12 - 2,3,4,7,8-PeCDF	85	50 - 130	30 - 150	YES	-
13C12 - 1,2,3,4,7,8-HxCDF	51	50 - 130	30 - 150	YES	-
13C12 - 1,2,3,6,7,8-HxCDF	60	50 - 130	30 - 150	YES	-
13C12 - 2,3,4,6,7,8-HxCDF	63	50 - 130	30 - 150	YES	-
13C12 - 1,2,3,4,6,7,8-HpCDF	47	40 - 130	20 - 150	YES	-
13C12 - OCDF	41	40 - 130	20 - 150	YES	-
Sampling standard	Recovery [%]	Acceptable range [%]		Rec. in range?	
13C12-1,2,3,7,8-PeCDF	79	> 50		YES	
13C12-1,2,3,7,8,9-HxCDF	67	> 50		YES	
13C12-1,2,3,4,7,8,9-HpCDF	69	> 50		YES	

Test Report No PW/21/06/21**9. CERTIFICATE OF ACCREDITATION****POLSKIE CENTRUM AKREDYTACJI**
POLISH CENTRE FOR ACCREDITATIONSygnatariusz EA MLA
EA MLA Signatory**CERTYFIKAT AKREDYTACJI**
LABORATORIUM BADAWCZEGO
ACCREDITATION CERTIFICATE OF TESTING LABORATORY**Nr AB 994**

Powierdza się, że. / This is to confirm that:

„PROFTECH” Sp. z o.o.
ul. Kurta Aldera 44, 41-506 Chorzówspełnia wymagania normy PN-EN ISO/IEC 17025:2018-02
meets requirements of the PN-EN ISO/IEC 17025:2018-02 standardAkredytowana działalność jest określona w Zakresie Akredytacji Nr AB 994
Accredited activity is defined in the Scope of Accreditation No. AB 994Akredytacja pozostaje w mocy pod warunkiem przestrzegania
wymagań jednostki akredytującej określonych w kontrakcie Nr AB 994
This accreditation remains in force provided the Laboratory observes
the requirements of Accreditation Body defined in the Contract No. AB 994Akredytacji udzielono dnia 30.01.2009 r.
Accreditation was granted on 30.01.2009DYREKTOR
POLSKIEGO CENTRUM AKREDYTACJI

LUCYNA OLBÓRSKA

Warszawa, dnia 6 grudnia 2019 roku

Test Report No PW/21/06/21

10. MEASUREMENT PLANE SCHEME

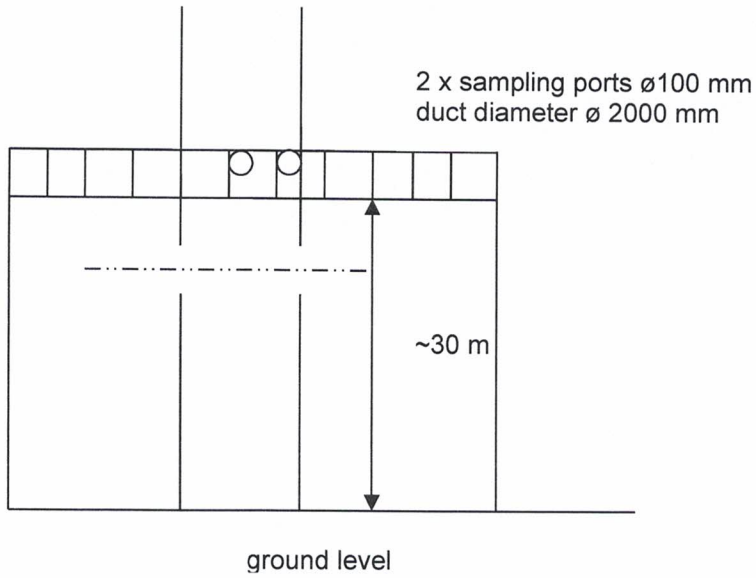

Approved by

DYREKTOR

Name and Signature

inż. Dariusz Guja

END OF REPORT