



PROFTECH

SPÓŁKA Z O.O.



AB 994

Research laboratory
accredited by PCA,
Nr AB 994

Scopes of accreditation:

- concentration and mass measurements of flow of fine particles
- measurements of concentration and mass flow of SO₂, NO_x, CO
- concentration measurements of CO₂, O₂
- concentration and mass flow measurements of OWO
- sampling for mass concentration determination of PCDD/PDF and dioxin type PCB
- sampling for concentration determination of (As; Cd; Cr; Co; Cu; Mn; Ni; Pb; Sb; Tl; V)
- sampling for concentration determination of Hg
- sampling and determination of concentration and mass flow of HCl
- sampling and determination of concentration and mass flow of HF
- sampling for determining the concentration of individual gaseous organic compounds
- calibration of Automated Monitoring systems,
- QAL2 procedure
- annual performance test of Automated Monitoring Systems, AST procedure
- noise measurement from machinery, installations and industrial plants

Chorzów, June 26th 2025
Our ref. No.: PW/59/06/25

Report No PW/59/06/25

on concentration measurements of heavy metals (As; Cd; Cr; Co; Cu; Mn; Ni; Pb; Sb; Tl; V) emitted into environment from flue gas channel located at UAB KAUNO KOGENERACINĖ JĖGAINĖ, Jėgainės g. 6, Biruliškių k., LT-54469 Kauno raj., Lithuania.

Client name and address:

**UAB KAUNO KOGENERACINĖ
JĖGAINĖ,**
Jėgainės g. 6, Biruliškių k.,
LT-54469 Kauno raj

Developed by:

mgr Grzegorz Bortel

Calculation and data transfer checked by:

inż. Dariusz Guja

Verified by:

Company manager - inż. Dariusz Guja

Copy number: ...1/2...

ul. Kurta Aldera 44
41-506 Chorzów
tel/fax: 0 32 247 37 24

www.proftech.com.pl
e-mail: proftech@proftech.com.pl

NIP: 627 252 46 31
KRS: 0000773369

bank account : PKO BANK POLSKI S.A. O/Katowice : IBAN PL62 1440 1172 0000 0000 0353 4332

Test Report No PW/59/06/25

List of contents:

- 1. PURPOSE AND SCOPE OF THE REPORT**
- 2. BASIS OF MEASUREMENTS EXECUTION**
- 3. MEASUREMENT TEAM**
- 4. MEASUREMENT RESULTS SUMMARY**
- 5. DESCRIPTION OF THE MEASUREMENT METHOD**
- 6. MEASUREMENT RESULTS**
- 7. MEASUREMENT DEVICES**
- 8. CERTIFICATE OF ACCREDITATION**
- 9. MEASUREMENT PLANE SCHEME**

Test Report No PW/59/06/25

1. PURPOSE AND SCOPE OF THE REPORT

Purpose of executed measurements was to determine the concentration of heavy metals (As; Cd; Cr; Co; Cu; Mn; Ni; Pb; Sb; Tl; V) emitted to environment from flue gas channel located at UAB KAUNO KOGENERACINĖ JĖGAINĖ, Jėgainės g. 6, Biruliškių k., LT-54469 Kauno raj., Lithuania

Measurements range:

- Heavy metals (As; Cd; Cr; Co; Cu; Mn; Ni; Pb; Sb; Tl; V) concentration,

The measurements were carried out in accordance with the sampling plan and the described sampling methods.

Operating parameters of the technological installation was obtained from the customer's representative.

2. BASIS OF MEASUREMENTS EXECUTION

The measurements were taken according to the contract No 2025-KKJ-63 dated April 25th 2025.

3. MEASUREMENT TEAM

The measurements taken on May 27th 2025 were executed by the following team:

- Grzegorz Bortel specialist - measurement team leader,
- Karol Sodo specialist,
- Przemysław Zubel specialist.

Test Report No PW/59/06/25

4. MEASUREMENT RESULTS SUMMARY

Below are presented measurement results summary, full measurement results are presented in chapter No 6, at page 7 and 8

Stationary emission source	Concentration of the substance in the gas in the reference conditions O2 ref. 11%	Cd*+Tl*	mg/m3 ref.	0,008
		Sb*+As*+Cr*+Co*+Mn*+Cu*+Ni*+Pb*+V*	mg/m3 ref.	0,052
	Emission limits	Cd+Tl	mg/m3 ref.	0,02
		Sb+As+Cr+Co+Mn+Cu+Ni+Pb+V	mg/m3 ref.	0,3
	Transgerssion	Cd+Tl	mg/m3 ref.	-
		Hg	mg/m3 ref.	-
Sb+As+Cr+Co+Mn+Cu+Ni+Pb+V		mg/m3 ref.	-	

*- the results obtained from the subcontractor (accredited)

Test Report No PW/59/06/25

5. DESCRIPTION OF THE MEASUREMENT METHOD**Measurement of the gas volumetric flow**

The flow rate and density of flue gases were determined according to Polish Standard PN-Z-04030-7:1994 „Testing of particulate content. The gravimetric method measurement of concentration and particulate mass flow in flue gases" Gravimetric dust monitor type MEGASYSTEM X-1 APIS and type "S" Pitot tube were used for the measurements. Measurement is accredited.

Accreditation range: differential pressure: > 10 Pa

Measurement O₂ content

The concentration of O₂ was determined using gas analyzer HORIBA PG-350E-HR equipped with testing probe 1500 mm long. The measurements were taken according to the procedure described in measurement unit as well as to EN Standard PN-EN 14789:2017 "Stationary source emissions - Determination of volume concentration of oxygen O₂ - Reference method - Paramagnetism". Measurement is accredited.

Accreditation range: O₂ content: 1,5-21%

Measurement CO₂ content

The concentration of CO₂ was determined using gas analyzer HORIBA PG-350E-HR equipped with testing probe 1500 mm long. The measurements were taken according to the procedure described in measurement unit as well as to ISO Standard ISO 10396:2007 "Stationary Source Emissions - Sampling For The Automated Determination Of Gas Concentrations ". Measurement is accredited.

Accreditation range: CO₂ content: 0,1-20%

Measurement of heavy metals content

Sampling for the determination of concentrations and emissions of heavy metals (Cd, Tl, Sb , As, Cr, Co, Cu , Mn , Ni , Pb, V) was performed according to PN -EN 14385 : 2005. Analysis of metals (Cd , Tl , Sb , As, Cr, Co, Cu , Mn , Ni , Pb, V) was performed in the laboratory of ŚCOP Sp. z o.o. in Czeladź , accredited in this regard by the Polish Centre of Accreditation No. AB 719

Test Report No PW/59/06/25

6. MEASUREMENT RESULTS

Test Report No PW/59/06/25

- 1) Plant or unit name¹⁾: **Combined Heat and Power Plant**
 2) Flue gases cleaning unit¹⁾: **Bag filters, activate carbon, hydrated lime, scrubber**
 3) Emission source load during measurements¹⁾: **Boiler load ~87,6 MW – 101,4%**
 4) Fuel type or material mass flow in process¹⁾: **75% municipal waste, 25% industrial waste**
 5) Location of sampling and measurements: **In duct, after flue gases cleaning unit**

Measurement reference number			27-05-01			X	X	X	
Date of measurement			27.05.2025						
Measurement time range			09:37-10:37	10:44-11:45	11:51-12:52				
Scope of test		Unit	Results			Average	Uncertainty +/-	Method	
Meteorological conditions	Atmospheric pressure	hPa	1006,2	1006,3	1006,2	1006,2	0,9	PN-Z-04030-7:1994	
	Air temperature	oC	18	18	19	18			
Measurement plane	Diameter	m	2,33						
	Area	m ²	4,2617						
Stack gas parameters	Temperature	oC	53,5	55,4	55,6	54,8	1,1		
	Static pressure	Pa	183,8	179,5	190,6	184,6	2,6		
	Dynamic pressure	Pa	128,6	125,0	124,8	126,1	1,5		
	Gas moistness grade X	kg/kg	0,122	0,122	0,122	0,122	0,0049		PN-EN 14790:2017
	Average velocity	m/s	12,8	12,6	12,6	12,6	0,2		PN-Z-04030-7:1994
	Chemical composition	O ₂	%	9,10	8,80	8,70	8,87		0,49
		CO ₂	%	10,00	10,20	10,40	10,20	0,39	ISO 10396:2007
	Wet gas density during testing	kg/m ³	1,038	1,033	1,033	1,035		PN-Z-04030-7:1994	
	Gas density in normal conditions	kg/m ³ N	1,248	1,248	1,249	1,248		PN-Z-04030-7:1994	
	Gas density in standard conditions	kg/m ³ U	1,338	1,339	1,340	1,339		PN-Z-04030-7:1994	
Concentration of the substance in the gas in reference conditions O ₂ ref. 11%	As gaseus*	mg/m ³ _{ref}	< 0,006629	< 0,005599	< 0,005489	< 0,005906	0,001392	PN-EN 14385:2005	
	As dust*	mg/m ³ _{ref}	< 0,000484	< 0,000482	< 0,000486	< 0,000484	0,000112	PN-EN 14385:2005	
	As*	mg/m ³ _{ref}	< 0,007113	< 0,006081	< 0,005975	< 0,006390	0,001396	PN-EN 14385:2005	
	Sb gaseus*	mg/m ³ _{ref}	< 0,006629	< 0,005599	< 0,005489	< 0,005906	0,001392	PN-EN 14385:2005	
	Sb dust*	mg/m ³ _{ref}	< 0,000484	< 0,000482	< 0,000486	< 0,000484	0,000112	PN-EN 14385:2005	
	Sb*	mg/m ³ _{ref}	< 0,007113	< 0,006081	< 0,005975	< 0,006390	0,001396	PN-EN 14385:2005	
	Cd gaseus*	mg/m ³ _{ref}	< 0,001326	< 0,001120	< 0,001098	< 0,001181	0,000189	PN-EN 14385:2005	
	Cd dust*	mg/m ³ _{ref}	< 0,000097	< 0,000097	< 0,000097	< 0,000097	0,000015	PN-EN 14385:2005	
	Cd*	mg/m ³ _{ref}	< 0,001423	< 0,001217	< 0,001195	< 0,001278	0,000190	PN-EN 14385:2005	
	Co gaseus*	mg/m ³ _{ref}	< 0,003315	< 0,002800	< 0,000549	< 0,002221	0,000433	PN-EN 14385:2005	
	Co dust*	mg/m ³ _{ref}	< 0,000242	< 0,000241	< 0,000243	< 0,000242	0,000037	PN-EN 14385:2005	
	Co*	mg/m ³ _{ref}	< 0,003557	< 0,003041	< 0,000792	< 0,002463	0,000435	PN-EN 14385:2005	
	Mn gaseus*	mg/m ³ _{ref}	0,006165	0,004928	0,005599	0,005564	0,000910	PN-EN 14385:2005	
	Mn dust*	mg/m ³ _{ref}	0,000198	0,000121	0,000263	0,000194	0,000031	PN-EN 14385:2005	
	Mn*	mg/m ³ _{ref}	0,006363	0,005049	0,005862	0,005758	0,000911	PN-EN 14385:2005	
	Cu gaseus*	mg/m ³ _{ref}	0,006430	0,005711	0,007027	0,006389	0,001063	PN-EN 14385:2005	
	Cu dust*	mg/m ³ _{ref}	0,003719	0,002687	0,002869	0,003092	0,000494	PN-EN 14385:2005	
	Cu*	mg/m ³ _{ref}	0,010149	0,008398	0,009896	0,009481	0,001172	PN-EN 14385:2005	
	Ni gaseus*	mg/m ³ _{ref}	< 0,003315	< 0,002800	< 0,002745	< 0,002953	0,000511	PN-EN 14385:2005	
	Ni dust*	mg/m ³ _{ref}	0,000653	< 0,000241	< 0,000243	0,000379	0,000063	PN-EN 14385:2005	
	Ni*	mg/m ³ _{ref}	0,003968	< 0,003041	< 0,002988	0,003332	0,000515	PN-EN 14385:2005	
	Pb gaseus*	mg/m ³ _{ref}	0,009082	0,006607	0,004556	0,006748	0,001754	PN-EN 14385:2005	
	Pb dust*	mg/m ³ _{ref}	< 0,000242	< 0,000241	< 0,000243	< 0,000242	0,000060	PN-EN 14385:2005	
	Pb*	mg/m ³ _{ref}	0,009324	0,006848	0,004799	0,006990	0,001755	PN-EN 14385:2005	

Test Report No PW/59/06/25

	V gaseus*	mg/m ³ _{ref}	< 0,006629	< 0,005599	< 0,005489	< 0,005906	0,001392	PN-EN 14385:2005
	V dust*	mg/m ³ _{ref}	< 0,000484	< 0,000482	< 0,000486	< 0,000484	0,000112	PN-EN 14385:2005
	V*	mg/m ³ _{ref}	< 0,007113	< 0,006081	< 0,005975	< 0,006390	0,001396	PN-EN 14385:2005
	Cr gaseus*	mg/m ³ _{ref}	< 0,005303	< 0,004480	< 0,004392	< 0,004725	0,001064	PN-EN 14385:2005
	Cr dust*	mg/m ³ _{ref}	< 0,000387	< 0,000386	< 0,000389	< 0,000387	0,000085	PN-EN 14385:2005
	Cr*	mg/m ³ _{ref}	< 0,005690	< 0,004866	< 0,004781	< 0,005112	0,001067	PN-EN 14385:2005
	Tl gaseus*	mg/m ³ _{ref}	< 0,006629	< 0,005599	< 0,005489	< 0,005906	0,001919	PN-EN 14385:2005
	Tl dust*	mg/m ³ _{ref}	< 0,000484	< 0,000482	< 0,000486	< 0,000484	0,000155	PN-EN 14385:2005
	Tl*	mg/m ³ _{ref}	< 0,007113	< 0,006081	< 0,005975	< 0,006390	0,001925	PN-EN 14385:2005
Gas volume flow	measurement conditions	m ³ /h	195612	193311	193157	194027	3573	PN-Z-04030-7:1994
	normal conditions	m ³ _n /h	162749	159923	159686	160786	2961	
	standard conditions	m ³ _{st} /h	135230	132867	132685	133594	2460	
	reference conditions O2 ref. 11%	m ³ _{ref} /h	160923	162097	163203	162074	7894	
Emission limits	Cd*+Tl*	mg/m ³ _{ref}	0,02					
	Sb*+As*+Cr*+Co*+Mn*+Cu*+Ni*+Pb*+V*	mg/m ³ _{ref}	0,3					
Concentration of the substance in the gas in reference conditions O2 ref. 11%	Cd*+Tl*	mg/m ³ _{ref}	0,008					
	Sb*+As*+Cr*+Co*+Mn*+Cu*+Ni*+Pb*+V*	mg/m ³ _{ref}	0,052					

*- the results obtained from the subcontractor (accredited)

1)-information obtained from the client

The notation "< or > y" where y=the value of the mesurand corresponding to the lower/upper limit of the measurement range of the method) means - a test result/result below or above the measurement range of the method. The lower/upper limit of the method's measurement range is assumed for the calculation, respectively. The expanded uncertainty shown is the measurement uncertainty for the value of the lower/upper limit of the measurement range of the method. In the case of converted test results/results obtained from a third-party provider of laboratory services, the measurement range limit of that provider's method is assumed for the calculation.

The measurement range limit for: Cr<0,80 ug/próbkę / As<1,00 ug/próbkę / Cd<0,20 ug/próbkę / Co<0,50 ug/próbkę / Mn<0,10 ug/próbkę / Cu<0,50 ug/próbkę / Ni<0,50 ug/próbkę / Pb<0,50 ug/próbkę / Tl<1,00 ug/próbkę / V<0,10 ug/próbkę / Sb<1,00 ug/próbkę

Notes:

Normal conditions designate the temperature of 273 K and pressure of 101,3kPa, defining normal cubic meter m³N. The standard conditions designate the temperature of 273K, pressure of 101,3 kPa and dry gases (steam contents less than 5 g/kg of flue gas), defining standard cubic meter, m³U

The specified expanded uncertainty comes from standard uncertainty multiplied by expansion coefficient k = 2, which provides 95% level of confidence for normal distribution. Uncertainty takes into account the sampling and analysis.

Registry of samples delivered to the laboratory: P/113/05/25 - P/122/05/25

Date of delivery to the laboratory: 29.05.2025

Date of analysis: 29.05.2025 - 06.06.2025

Field blanks:

ID/ number of sample	Type of substance	The criterion of the blank [mg/m ³] 11%O ₂	The value of the blank [mg/m ³] 11% O ₂	Result [+/-]
P/119/05/25	Cd+Tl	0,002	p.o.	+
P/119/05/25	Sb+As+Pb+Cr+Co+Cu+Mn+Ni+V	0,03	p.o.	+

p.o. – below the limit of quantification.

Test Report No PW/59/06/25

Work parameters of measurement system:**Heavy metals (PN-EN 14385:2005)**

Sampling plane: 2 measurement axis
Sampling: isokinetic [x]
nonisokinetic []
Isokinetic ratio: 108,3 % / 107,6 % / 106,2 %
Sampling time: 60,1 min / 60,2 min / 60,1 min
Sampled volume: 0,106 / 0,122 / 0,123 m³
Filter parameters: FT-50: Ø 0,50 mm, efficiency: 99,990 %, quartz (QMA)
Impingers: impingers set No. 1 (absorption efficiency 98,5 %)
Absorption solution: HNO₃/H₂O₂

H₂O (PN-EN 14790:2017)

Sampling plane: 2 measurement axis
Sampling equipment: titanium sampling line
heated probe 2,0 m
sampling pump: AQUARIA
Cartridge No: H₂O content set No 1
Sampling No: 1
Sampling time: ~60 min
Sampling speed: ~2,0 l/min
H₂O maas: 14,5 g
absrobtion efficiency: 98,9 %

Test Report No PW/59/06/25

O₂ paramagnetic (PN-EN 14789:2017):

Range :	0 – 5 %	[]	
	0 – 10 %	[X]	
	0 – 25 %	[]	
Calibration gas:	O ₂ – 8,001%	[X]	R/07/W
	O ₂ – 20,018%	[]	R/12/W
	N ₂ – 99,99%	[X]	R/17/
Sampling train:	2 measurement axis		
Sampling time/ average time:	180 min / 1 min		

O ₂ concentration measurement (paramagnetic):		HORIBA PG-350E-HR			
check operation		unit	result	criterion	result +/-
„0” after adjustment, without sampling train		%	0,05	± 0,1 [%]*	+
„0” after adjustment, with sampling train	before measurement	%	0,1	± 0,2 [%]**	+
	after measurement	%	0,1	± 0,2 [%]**	+
„Span” after adjustment with sampling train /standard 8,001 % R/07/W analyser range 10%/	before measurement	%	7,95	± 0,2 [%]**	+
	after measurement	%	8,00	± 0,2 [%]**	+
	before measurement time T90	%	7,2	> 7,2 [%]	-----
sec.		20	< 200 sec.	+	

*2 x repeatability „0”; **2% measurement range

Test Report No PW/59/06/25

7. MEASUREMENT DEVICES

Name of measuring device	POBORNIK IZOKINETYCZNY
Type of measuring device	X1-APIS PLUS nr 0192
Calibration Certificate No, Date of issue	2054/696/LA/T/2024 09.10.2024 r. G-401/24-254/24 07.10.2024 r. 1074/409/LA/P/2024 08.10.2024 r.
Issued by	PLUM Sp. z o.o. KLEOSIN ZAP BESTWINKA

Name of measuring device	HORIBA
Type of measuring device	PG-350E-HR
Calibration Certificate No, Date of issue	79/1/AW/25 13.03.2025 r.
Issued by	LABOSERWIS SP. Z O.O. KATOWICE

Name of measuring device	AQUARIA CF 20
Type of measuring device	GAZOMIERZ MIECHOWY
Calibration Certificate No, Date of issue	G-357/23-245/23 18.09.2023 r. 881/336/LA/P/2023 15.09.2023 r. 233/1/T/23 06.09.2023 r.
Issued by	LABOSERWIS Sp. z o.o. KATOWICE PLUM Sp. z o.o. KLEOSIN ZAP J.FIRGANEK BESTWINKA

Test Report No PW/59/06/25**8. CERTIFICATE OF ACCREDITATION****POLSKIE CENTRUM AKREDYTACJI**
POLISH CENTRE FOR ACCREDITATIONSygnatariusz EA MLA
EA MLA Signatory**CERTYFIKAT AKREDYTACJI**
LABORATORIUM BADAWCZEGO
ACCREDITATION CERTIFICATE OF TESTING LABORATORY
Nr AB 994

Potwierdza się, że. / This is to confirm that:

„PROFTECH” Sp. z o.o.
ul. Kurta Aldera 44, 41-506 Chorzówspełnia wymagania normy PN-EN ISO/IEC 17025:2018-02
meets requirements of the PN-EN ISO/IEC 17025:2018-02 standardAkredytowana działalność jest określona w Zakresie Akredytacji Nr AB 994
Accredited activity is defined in the Scope of Accreditation No AB 994Akredytacja pozostaje w mocy pod warunkiem przestrzegania
wymagań jednostki akredytującej określonych w kontrakcie Nr AB 994
This accreditation remains in force provided the Laboratory observes
the requirements of Accreditation Body defined in the Contract No AB 994Akredytacji udzielono dnia 30.01.2009 r.
Accreditation was granted on 30.01.2009DYREKTOR
POLSKIEGO CENTRUM AKREDYTACJI
LUCYNA OLBORSKA

Warszawa, dnia 9 grudnia 2019 roku

Test Report No PW/59/06/25

9. MEASUREMENT PLANE SCHEME

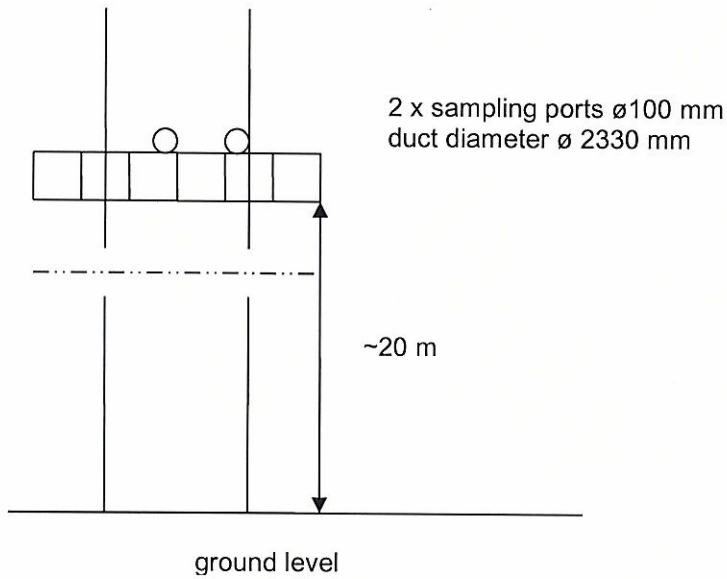

DYREKTOR
Approved
inż. Dariusz Guja
.....
Name and Signature

END OF REPORT

